

SCIM7B37

Non-Linearized Isolated Thermocouple Input Modules

Description

SCIM7B37 thermocouple input module is a single channel of input from type J,K,T,E,R,S,or B thermocouples which if filtered, isolated, amplified, and converted to standard-level voltage output. A five pole filter is provided with signal filtering which provides up to 85dB NMR at 50/60Hz

cold junction compensation (CJC) is performed using an NTC thermistor (see "Additional SCIM7B Part Number" section for P/ and AN701 for further information) externally mounted under the field-side terminal block on the backpanel (Figure 1). Open thermocouple detection is upscale using a 30nA current source in the input circuitry.

The input signal is chopped by a proprietary converter circuit. After initial filter stage isolation is provided by transformer coupling which eliminates common mode spikes and surges. The signal is then reconstructed and filtered for process control system output.

These modules accepts a wide 14 - 35VDC power supply range (+24VDC nominal). The mechanical size (2.13"x1.705"x0.605" max.) save space and are ideal for high channel density applications. They are designed for easy DIN Rail mounting using nay of the "DIN" backpanels.

Features

- Interfaces to Type J, K, T, E, R, S, and B thermocouples.
- Standard Output of either 0 to 10V/+10V, 0 to 5V, 1 to 5V.
- 1.5KV Isolation.
- Accuracy $\pm 0.03\%$ of Span typical, $\pm 0.1\%$ Max.
- ANSI/IEEE C37.90.1 Transient Protection
- 120V rms Continuous Protected on Input
- Noise, 500uV Peak (5MHz), 250uV rms (100KHz)
- 160dB CMRR
- NMR, up to 85dB
- Easy DIN Rail Mounting
- CSA, FM, CE and ATEX Compliant

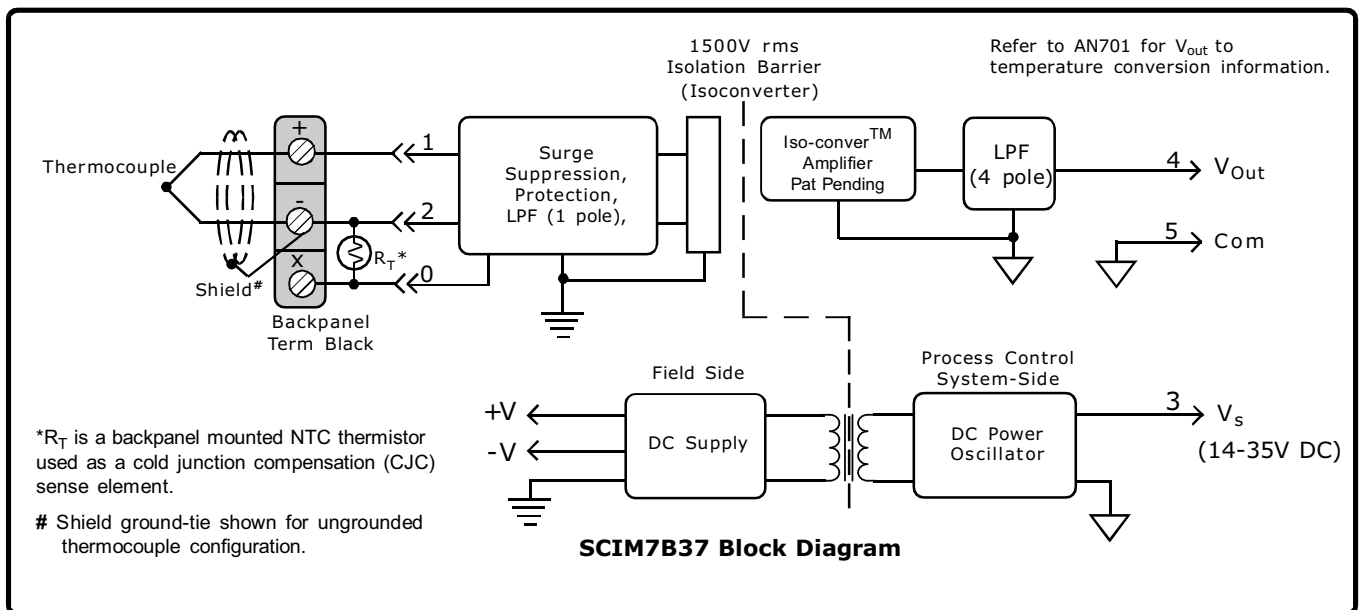

Specifications Typical at T_A=+25°C and +5V Power supply

Module	SCIM7B37
Input	
Signal Range	Thermocouple ⁽¹⁾ (See Ordering information)
Bias current	-30 nA
Resistance	
Normal	50MΩ
Power off	30KΩ min
Overload	30KΩ min
Protection	
Continuous	120V rms max.
Transient	ANSI/IEEE C37.90.1
Output	
Signal Range ⁽²⁾	See Ordering Information
Effective available power ⁽²⁾	40μΩ
Resistance	<1Ω
Protection	Continuous short to ground
Voltage/Current Limit	±16V, ±14mA
CMV (Input to Output)	
Continous	1500V rms
Transient	ANSI/IEEE C37.90.1
CMRR (50 or 60Hz)	160dB
Accuracy ⁽³⁾	±0.03% Span typical ±0.1% Span max
Nonlinearity ⁽⁴⁾	See Ordering Information
Stability (-40°C to +85°C)	
Gain	±35ppm/°C
Input Offset	±0.5uV/°C
Zero Suppression	±0.005%(V _Z) ⁽⁵⁾ /°C
Output Offset	±0.002% Span/°C
Noise	
Peak at 5MHz B/W	500uV
RMS at 10Hz to 100KHz B/W	250uV
Peak at 0.1Hz to 10Hz B/W	1uV RTI
CJC Accuracy ⁽⁴⁾	±0.25% typ, ±1°C max
+5°C to +45°C ambient	
Open Input Response	Upscale
Open Input Detection Time	<10s
Frequency and Time Response	
Bandwidth, -3dB	3Hz
NMR (50/60Hz)	80/85dB
Step Response, 90% span	165ms
Power supply voltage	14 to 35V DC
Power supply Current ⁽²⁾	12 mA
Power supply Sensitivity	±0.0001%/V _S
Mechanical Dimensions (H) (W) (D)	2.13"x1.705"x0.605"max (54.1x43.3x15.4mm)max
Environmental	
Operating Temp. Range	-40°C to +85°C
Storage Temp. Range	-40°C to +85°C
Relative Humidity	0 to 95% Noncondensing
Emissions EN61000-6-4	ISM, Group 1
Radiated, Conducted	Class A
Immunity EN61000-6-2	ISM, Group 1
RF	Performance A ±0.5% Span
ESD,EFT,Surge,	Error
Voltage Dips	Performance B

Note:

- (1). Thermocouple characteristics NIST monograph 175, ITS-90.
- (2). Output range and supply current specifications are based on minimum output load resistance. Minimum output load resistance is calculated by V_{out}^2/P_E , where P_E is the output effective available power that guarantees output range, accuracy, and linearity, specifications.
- (3). Accuracy includes the effects of repeatability, hysteresis, and conformity.
- (4). Non-linearity is calculated using the best-fit straight line method.
- (5). V_Z is the nominal input voltage results in a 0V output.
- (6). The CJC sensor accuracy should be added to the module accuracy and thermocouple accuracy to compute the overall measurement accuracy.

Ordering Information

Model	Input Range	Accuracy		Nonconformity ⁽⁴⁾		Output Range
		Typical	Max	Typical	Max	
SCIM7B37J-01	-100°C to +760°C (-148°F to +1400°F)	±0.03% (0.26°C)	±0.1% (0.86°C)	±0.01% (0.09°C)	±0.02% (0.17°C)	1, 2, 3, 4, 5
SCIM7B37J-10	0°C to +200°C (+32°F to +392°F)	±0.03% (0.06°C)	±0.1% (0.20°C)	±0.01% (0.02°C)	±0.02% (0.04°C)	1, 2, 3, 4, 5
SCIM7B37J-11	0°C to +400°C (+32°F to +752°F)	±0.03% (0.12°C)	±0.1% (0.40°C)	±0.01% (0.04°C)	±0.02% (0.08°C)	1, 2, 3, 4, 5
SCIM7B37J-12	0°C to +600°C (+32°F to +1112°F)	±0.03% (0.18°C)	±0.1% (0.60°C)	±0.01% (0.06°C)	±0.02% (0.12°C)	1, 2, 3, 4, 5
SCIM7B37J-13	300°C to +600°C (-572°F to +1112°F)	±0.03% (0.09°C)	±0.1% (0.30°C)	±0.01% (0.03°C)	±0.02% (0.24°C)	1, 2, 3, 4, 5
SCIM7B37K-02	-100°C to +1350°C (+148°F to +2462°F)	±0.03% (0.44°C)	±0.1% (1.45°C)	±0.01% (0.15°C)	±0.02% (0.29°C)	1, 2, 3, 4, 5
SCIM7B37K-20	0°C to +300°C (+32°F to +572°F)	±0.03% (0.09°C)	±0.1% (0.30°C)	±0.01% (0.03°C)	±0.02% (0.06°C)	1, 2, 3, 4, 5
SCIM7B37K-21	0°C to +600°C (+32°F to +1112°F)	±0.03% (0.18°C)	±0.1% (0.60°C)	±0.01% (0.06°C)	±0.02% (0.12°C)	1, 2, 3, 4, 5
SCIM7B37K-22	0°C to +1200°C (+32°F to +2192°F)	±0.03% (0.36°C)	±0.1% (1.20°C)	±0.01% (0.12°C)	±0.02% (0.24°C)	1, 2, 3, 4, 5
SCIM7B37K-23	600°C to +1200°C (+1112°F to +2192°F)	±0.03% (0.18°C)	±0.1% (0.60°C)	±0.01% (0.06°C)	±0.02% (0.12°C)	1, 2, 3, 4, 5
SCIM7B37T-03	-100°C to +400°C (-148°F to +752°F)	±0.03% (0.15°C)	±0.1% (0.50°C)	±0.01% (0.05°C)	±0.02% (0.10°C)	1, 2, 3, 4, 5
SCIM7B37E-04	0°C to +900°C (+32°F to +1652°F)	±0.03% (0.27°C)	±0.1% (0.90°C)	±0.01% (0.09°C)	±0.02% (0.18°C)	1, 2, 3, 4, 5
SCIM7B37R-05	0°C to +1750°C (+32°F to +3182°F)	±0.03% (0.53°C)	±0.1% (1.75°C)	±0.01% (0.18°C)	±0.02% (0.35°C)	1, 2, 3, 4, 5
SCIM7B37S-06	0°C to +1750°C (+32°F to +3182°F)	±0.03% (0.53°C)	±0.1% (1.75°C)	±0.01% (0.18°C)	±0.02% (0.35°C)	1, 2, 3, 4, 5
SCIM7B37B-07	0°C to +1800°C (+32°F to +3272°F)	±0.03% (0.54°C)	±0.1% (1.80°C)	±0.01% (0.18°C)	±0.02% (0.36°C)	1, 2, 3, 4, 5

Output Ranges Available

Output Range	Part No. Suffix	Example
1. 1 to +5V	NONE	SCIM7B37J-01
2. 0 to +5V	A	SCIM7B37J-01A
3. 0 to +10V	D	SCIM7B37J-01D
4. -5V to +5V	C	SCIM7B37J-01C
5. -10V to +10V	B	SCIM7B37J-01B

***Thermocouple Alloy Combinations**

Standards: DIN IEC 584, ANSINC96-182, JIS C 1602-1981

Type	Materials
J	Iron vs. Copper-Nickel
K	Nickel-Chromium vs. Nickel-Aluminium
T	Copper vs. Copper-Nickel
E	Nickel-Chromium vs. Copper-Nickel
R	Platinum-13% Rhodium vs. Platinum
S	Platinum-10% Rhodium vs. Platinum
B	Platinum-30% Rhodium vs. Platinum-6% Rhodium